



GLOBAL AUTOMATE SOLUTIONS

Increase Your Shop Floor Efficiency With Us!!!

Leveling Caster Wheel

Global Automate Solutions is a Professional Manufacturer of T Slot Aluminum Profiles & Accessories and Non-standard fasteners. The company is located in Pune city Maharashtra –India

The company firmly set up the concept of “quality first, credibility foremost”! Relying on the scientific management method, the company optimizes the supply chain, improves and explores new processing technics, brings in advanced processing equipment, and reduces production cost without compromising the quality of products to really benefit our customers.

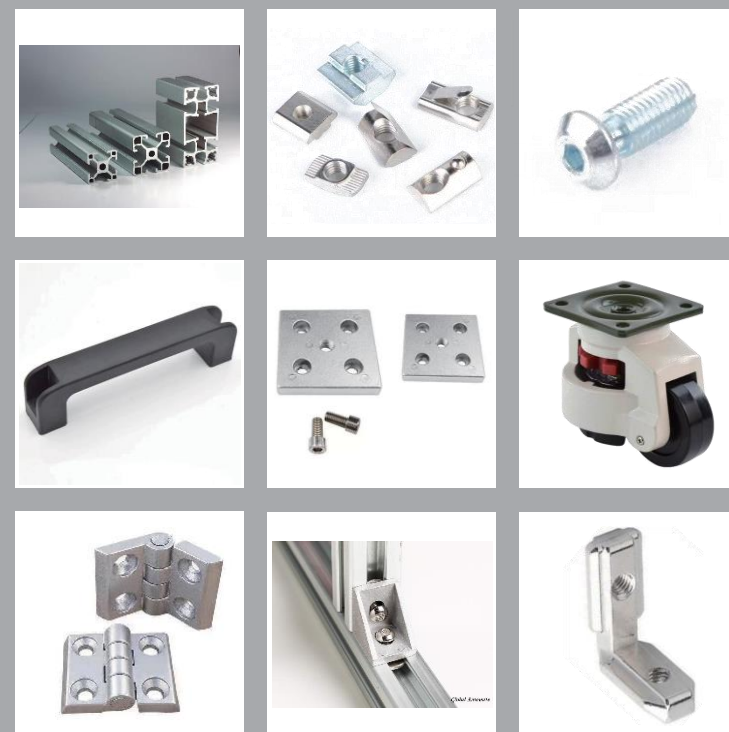

T SLOT
ALUMINIUM
PROFILE &
ACCESSORIES

Contact Us –

Global Automate Solutions
95/1 Near Swami Samarth temple landgenagar Bhosari Pune 411039
Tel - +917972221755 / 9730382785/ 9850763285
Mail – salesglobalautomate@gmail.com
website - www.globalautomate.in

Leveling Caster Wheel

GD 40 LEVELING CASTER WHEEL

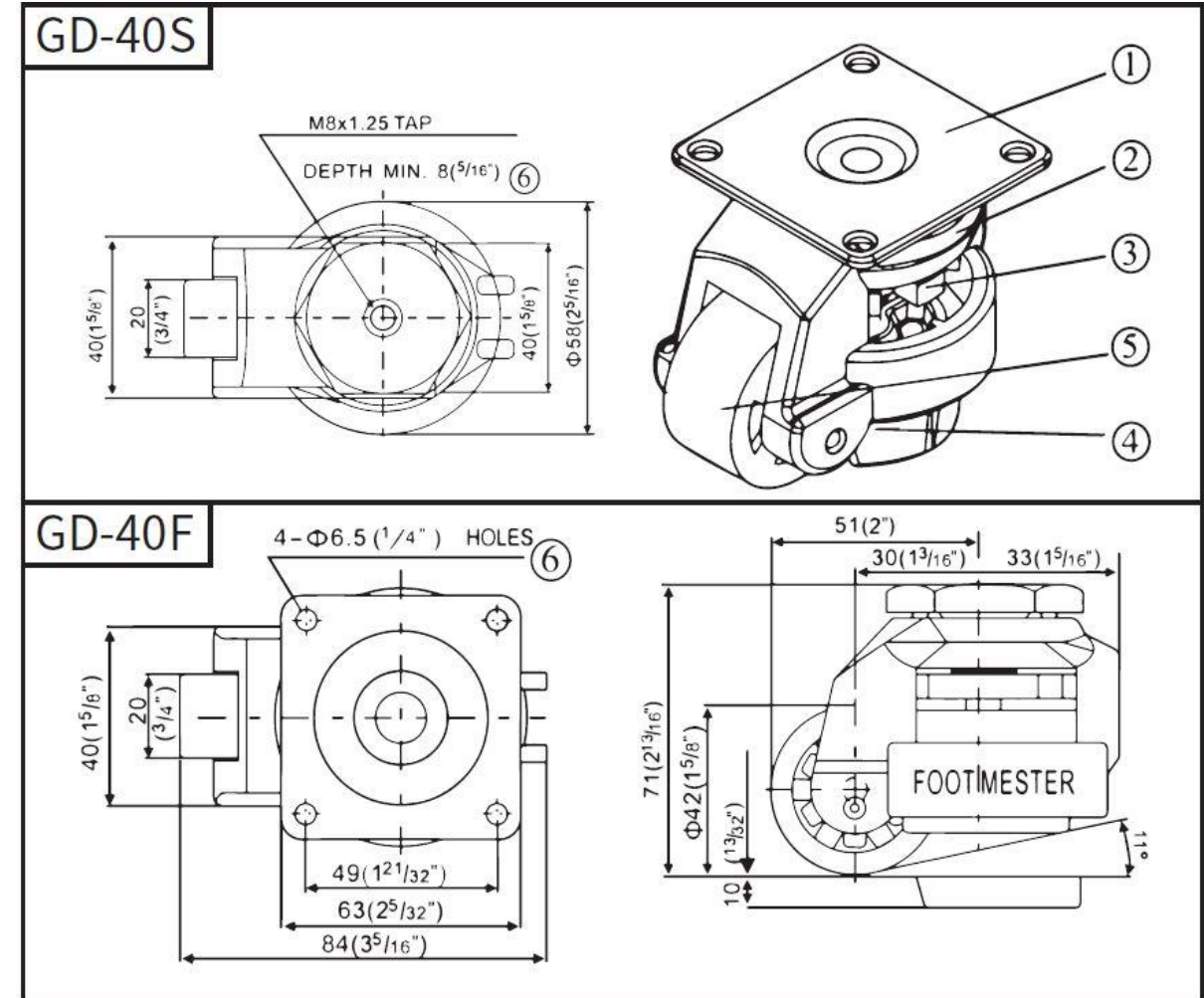

Model	Material :								
	①Carbon steel stamping			②Aluminum alloy			③MC Nylon		
	④NBR		⑤MC Nylon		⑥Surface treatment : Spraying & Galvanizing				
GD-40S	Recommended load/4pcs	Load capacity/pc	Wheel Diameter	Bolt Size		Overall Height	Adjustable range	Mass/kg	Part No
	100 kg	50 kg	42 mm	M8×10		71 mm	10 mm	0.35	91040
GD-40F	Recommended load/4pcs	Load capacity/pc	Wheel Diameter	Plate Hole Centers	Size of Plate	Overall Height	Adjustable range	Mass/kg	Part No
	100 kg	50 kg	42 mm	49×49	63×63	71 mm	10 mm	0.35	91041

Leveling Caster Wheel

GD 60 LEVELING CASTER WHEEL

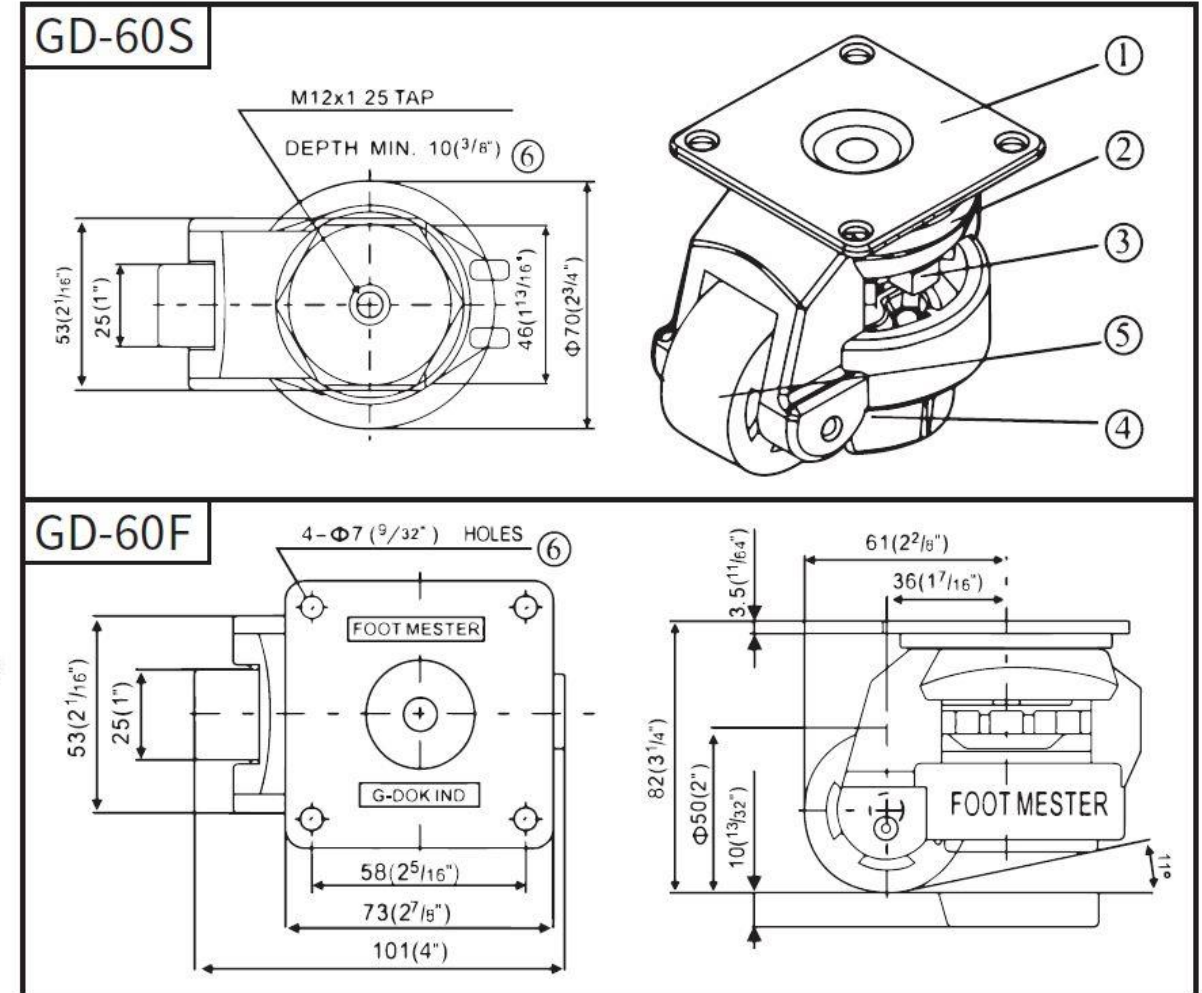

Model	Material :									
	①Carbon steel stamping			②Aluminum alloy		③MC Nylon			④NBR ⑤MC Nylon ⑥Surface treatment : Spraying & Galvanizing	
GD-60S	Recommended load/4pcs	Load capacity/pc	Wheel Diameter	Bolt Size		Overall Height	Adjustable range	Mass/kg	Part No	
	500 kg	250 kg	50 mm	M12×15		82 mm	10 mm	0.7	91042	
GD-60F	Recommended load/4pcs	Load capacity/pc	Wheel Diameter	Plate Hole Centers	Size of Plate	Overall Height	Adjustable range	Mass/kg	Part No	
	500 kg	250 kg	50 mm	58×58	73×73	782mm	10 mm	0.7	91043	

Leveling Caster Wheel

GD 80 LEVELING CASTER WHEEL

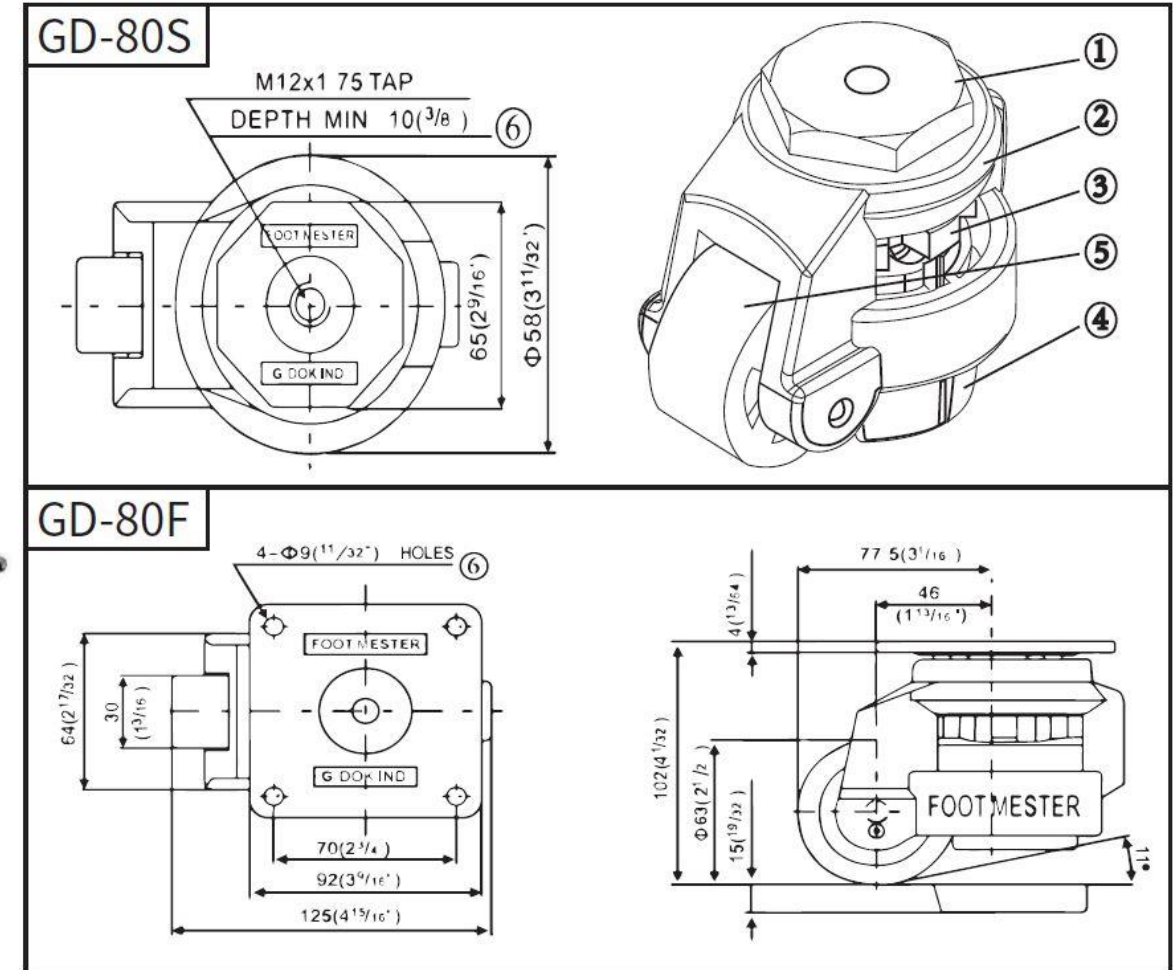

Model	Material :									
	①Carbon steel stamping			②Aluminum alloy		③MC Nylon			④NBR ⑤MC Nylon ⑥Surface treatment : Spraying & Galvanizing	
GD-80S	Recommended load/4pcs	Load capacity/pc	Wheel Diameter	Bolt Size		Overall Height	Adjustable range	Mass/kg	Part No	
	1000 kg	500 kg	63 mm	M12×15		102 mm	15 mm	1.3	91044	
GD-80F	Recommended load/4pcs	Load capacity/pc	Wheel Diameter	Plate Hole Centers	Size of Plate	Overall Height	Adjustable range	Mass/kg	Part No	
	1000 kg	500 kg	63 mm	70×70	90×90	102 mm	15 mm	1.3	91045	

Leveling Caster Wheel

GD 100 LEVELING CASTER WHEEL

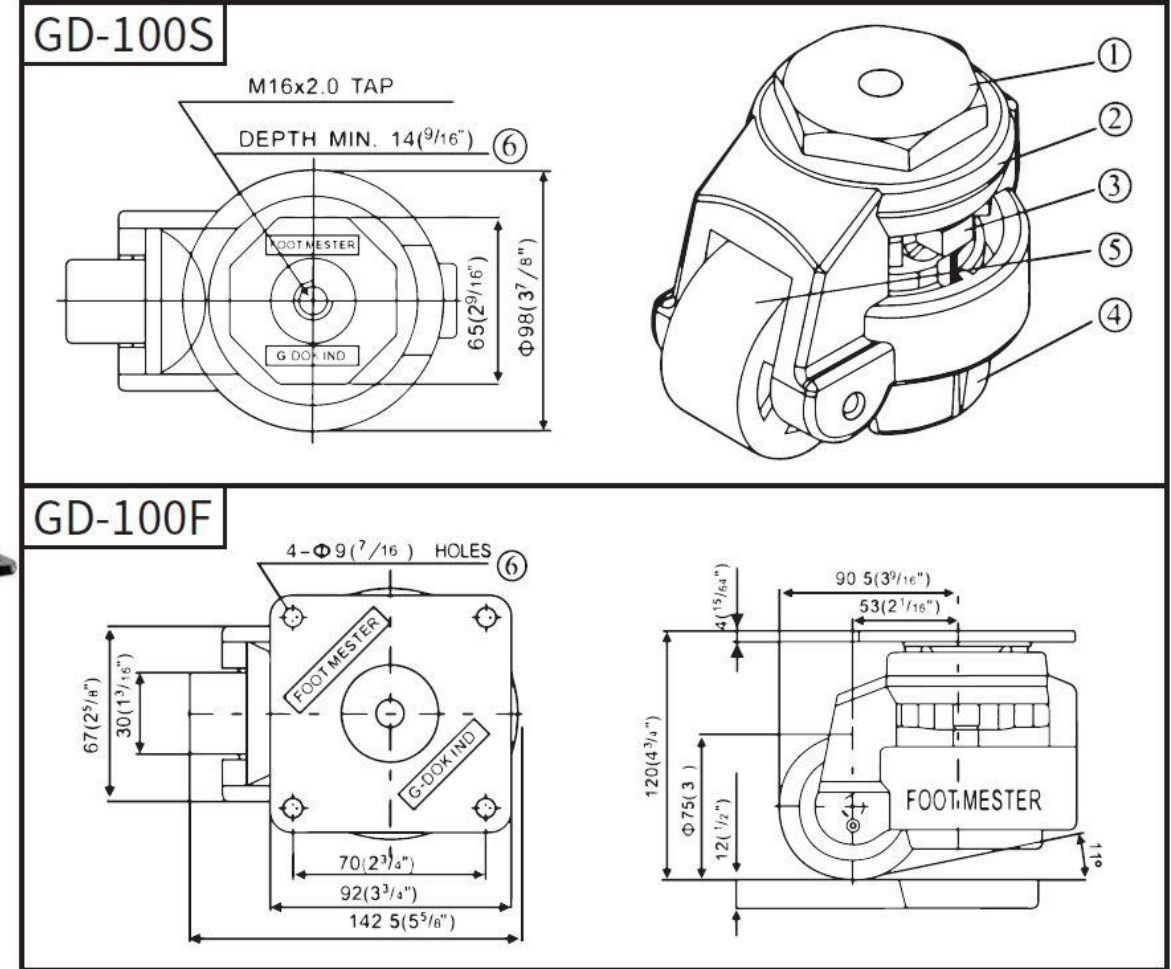

Model	Material :									
	①Carbon steel stamping			②Aluminum alloy		③MC Nylon			④NBR ⑤MC Nylon ⑥Surface treatment : Spraying & Galvanizing	
GD-100S	Recommended load/4pcs	Load capacity/pc	Wheel Diameter	Bolt Size		Overall Height	Adjustable range	Mass/kg	Part No	
	1500 kg	750 kg	75 mm	M16×20		120 mm	12 mm	1.75	91046	
GD-100F	Recommended load/4pcs	Load capacity/pc	Wheel Diameter	Plate Hole Centers	Size of Plate	Overall Height	Adjustable range	Mass/kg	Part No	
	1500 kg	750 kg	75 mm	70×70	92×92	120 mm	12 mm	1.75	91047	

Leveling Caster Wheel

GD 120 LEVELLING CASTER WHEEL

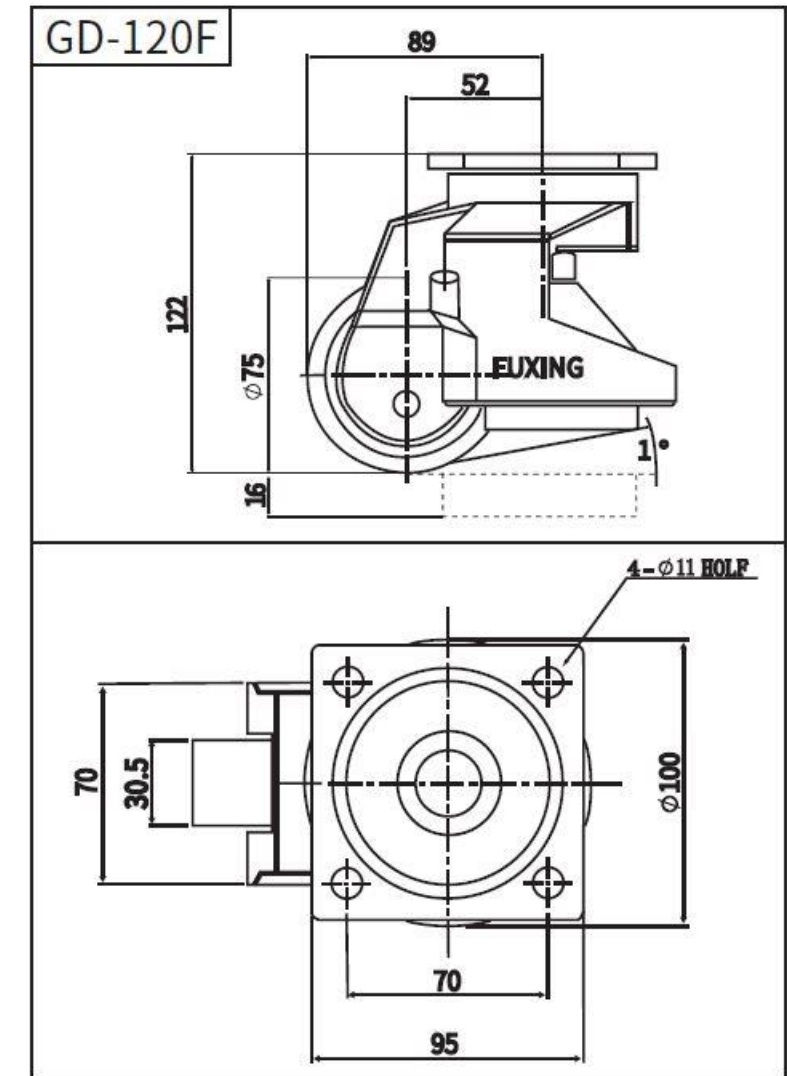

Model	Material :								
	①Carbon steel stamping ②Aluminum alloy ③MC Nylon ④NBR ⑤Surface treatment : Spraying & Galvanizing								
GD-120F	Recommended load/4pcs	Load capacity/pc	Wheel Diameter	Plate Hole Centers	Size of Plate	Overall Height	Adjustable range	Mass/kg	Part No
	2000 kg	1000 kg	75 mm	70×70	95×95	120 mm	12 mm	1.73	91048